

# Economic Analysis and Sustainability Study of a Coffee Production Process in Line with Circular Economy

Sokratis E. Koskinakis\*, Christina Drosou, Christos Boukouvalas, Magdalini Krokida

National Technical University of Athens, School of Chemical Engineering, Iroon Polytechniou 9, Zografou Campus, 15780, Athens, Greece  
 sekoskinakis@mail.ntua.gr

The coffee industry is raising environmental concerns around the world due to the high energy consumption and waste produced from processing coffee beans. The highest energy consumption is the roasting stage, which utilizes thermal energy from burning fossil fuels to heat the air to a temperature of around 220 °C. This hot stream is usually vented to the atmosphere. Additionally, the process produces a by-product known as 'silverskin', which is commonly discarded to landfills or gets incinerated by most industries as a waste. This by-product has the potential to be exploited for the generation of high value-added products, due to its high content in antioxidant compounds. In this study, energy-saving solutions related to hot stream recycling and the valorization of silverskin by-product were evaluated in the context of sustainability and circular economy. The proposed solutions of the present work include the installation of a heat pump for the pre-roasting of the coffee beans, resulting in a reduction in usage of fossil fuels and the incorporation of innovative extraction techniques for the recovery of valuable compounds, such as phenolics and flavonoids. Moreover, an economic analysis of the proposed solutions was carried out with the aim of evaluating the economic feasibility and sustainability of this specific investment project. Finally, scale-up experiments were performed to evaluate the impact of the proposed methodologies in a conventional coffee production line.

## 1. Introduction

Coffee is the second most traded product in the world after fossil fuels. According to the International Coffee Organization (INTERNATIONAL COFFEE ORGANIZATION 2020), in the year 2020-2021 the global consumption of coffee was approximately 167 million 60 kg bags, a figure that is expected to increase in the upcoming years. The consumption of coffee as an everyday beverage is linked with numerous positive effects related to human health, such as elevated energy levels and mental alertness (Sargent et al. 2020), reduced risk of developing certain diseases (Costabile et al. 2018), and protection from free radicals due to its antioxidant properties (Liang and Kitts 2014).

Following the cultivation of the coffee plants, the processing of the green coffee beans is mandatory prior to their consumption. The most crucial stage of the processing is the roasting of the raw beans (Figure 1). For the roasting of the beans, natural gas is utilized to heat the air waves from the atmosphere inside a furnace. The hot air streams, along with some additional fresh air, are then transferred inside a roasting chamber together with the raw coffee beans, for approximately 10-20 minutes, depending on the desired type of roasting. Finally, the roasted coffee beans are transferred to a cooling tray in order to preserve their flavor and aroma. Roasting of coffee beans results in the generation of two types of wastes: coffee silverskin, which constitutes 1-2 % of the original mass of the coffee bean and a hot air stream consisting of volatile organic compounds (VOC) and particulate matter (PM). The aforementioned by-products are transferred to a cyclone in order to get separated, with the hot air current being placed in an afterburner to remove the VOCs and PMs, prior to being discharged in the atmosphere.

The discharged hot air stream can be valorized towards the production of clean energy via a reverse heat pump and more specifically, an organic Rankine cycle (ORC). Depending on the type of afterburner (thermal

or catalytic), the temperature of this waste stream can vary from 400 °C to 800 °C. More specifically, the thermal afterburner operates in high temperatures to oxidize the VOCs, with the gas stream being transferred into a combustion chamber and then heated to a temperature between 815 °C to 982 °C to initiate combustion. The catalytic afterburner uses a catalyst to accelerate the oxidation of the VOCs at lower temperatures, typically between 260 °C to 427 °C, where the catalyst promotes the reaction between the VOCs and oxygen (Schwartzberg 2013).

Coffee silverskin is usually disposed as solid waste in landfills generating serious environmental problems due to its high carbon content (Mussatto et al. 2011). However, it could be exploited in order to extract valuable bioactive compounds, such as polyphenols, making it a valuable source of natural antioxidants (Murthy and Naidu 2012; Costa et al. 2018).

The aim of the present work is to study the valorization of the originated wastes during coffee roasting and to assess their economic feasibility in two different case studies. Moreover, the generation of electrical energy using an ORC is evaluated, as well as the recovery of phenolic compounds via extraction from silverskin residues.

In the first case study, a small-scale coffee plant, utilizing a thermal afterburner, is examined with its daily production of roasted coffee beans and residual silverskin reaching up to 1,400 kg and 21 kg, respectively. In the latter case study, a large-scale coffee plant, utilizing a catalytic afterburner, is examined with its daily production of roasted coffee beans and residual silverskin reaching up to 4,200 kg and 42 kg, respectively.

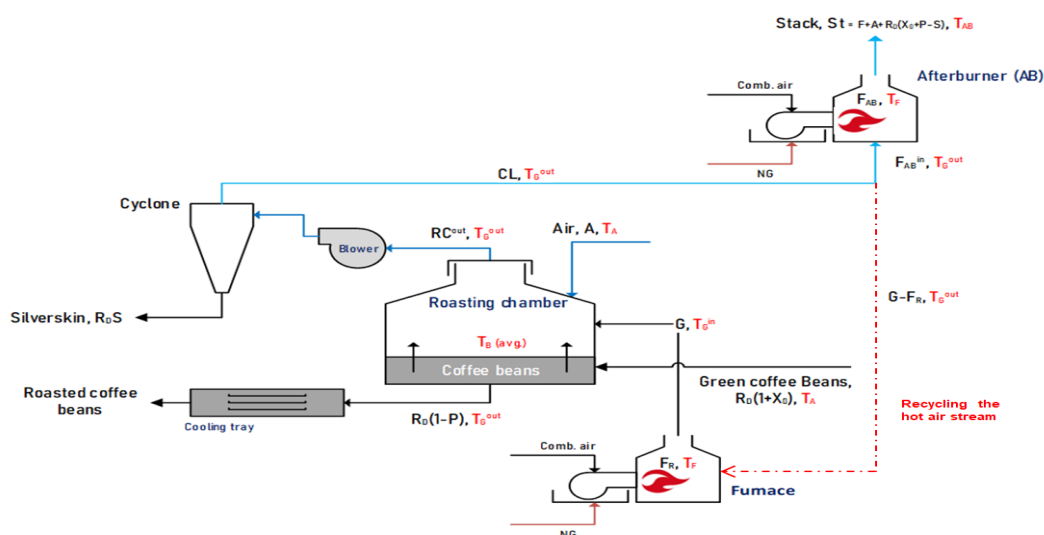

Figure 1. Roasting process of green coffee beans

## 2. Materials and Methods

### 2.1. Valorization of the hot streams

Waste heat produced from the afterburner was used to generate clean energy with the help of an Organic Rankine Cycle (ORC). ORC is a thermodynamic cycle used to generate electricity from heat sources at low temperatures. It includes a pump to circulate an organic fluid (a refrigerant) through a closed loop system, where the fluid is heated in a heat exchanger, which causes the fluid to vaporize. The vaporized fluid is driven to a turbine and generates electricity and then it is cooled in another heat exchanger, causing it to condense back into a liquid, and the cycle starts over again (Markides 2013).

ASPEN plus software was focused solely to simulate the instalment of an ORC heat pump at the end of the afterburner for the two case studies and did not include the valorization of silverskin. The data utilized in this simulation, were obtained through a custom simulator of the roasting process developed in MS excel (table 1), based in energy and mass balances equations outlined in the work by Schwartzberg (2013) and the information provided by Loumidis Coffee shop, Greece for the small-scale plant and literature (Pantaleo et al. 2018) for the large-scale plant. All the physical and chemical properties of the materials used were provided by the library of Aspen and the thermodynamic calculation were performed according to the REFPROP model (Ong'iro et al. 1995). The calculations were conducted under the assumption that the VOCs contained in the flue gas, upon leaving the afterburner, underwent near-complete oxidation and did not affect the heat capacity value of the gas stream entering the organic Rankine cycle (ORC) in both studied scenarios.

Water was used as a refrigerant in the small-scale plant simulation due to the high temperature of the heat source and its abundance. The refrigerant used in the large-scale plant was 1,3,3,3 -Tetrafluoropropene (R1234ZE) due to its lower boiling point (9.8 °C) and its efficiency in lower temperatures.

Table 1: Case studies of different factories at 1h of operation

Case study	Small-scale plant	Large-scale plant
Green coffee beans $R_D$ (kg)	225	450
Roaster type	SP	RP
Afterburner	Thermal	Catalytic
Afterburner stack temperature (°C)	760	400
Air input ratio A/RD(kg air/kg d beans)	2.199	0.408
Silverskin (kg)	2.1	3.6
Recycling air before afterburner	No	Yes
Quenching	Outside chamber	Inside chamber
Stack air St (kg)	1,620 kg	720 kg
Refrigerant	Water	R1234ZE

## 2.2. Extraction of bioactive compounds from coffee silverskin

Coffee silverskin (Coffee Arabica and Robusta) with 1-2 % moisture was kindly provided by Loumidis coffee roasting plant located in Athens, Greece. The samples were grinded using an electric-knives mill and then put in sieves until the particles were the size of 1mm. The grinded samples were stored at plastic tubes until the extraction process.

In the present work three different types of extraction with two solvent systems (ethanol 50:50 water and methanol 80:20 water) were applied in order to extract the bioactive compounds of silverskin: Soxhlet extraction, Conventional extraction with a hot plate and magnetic stirring and Ultrasonic Assisted Extraction (UAE).

Soxhlet was performed for the sole purpose of calculating the maximum yield of the extraction process, as it is an exhaustive but costly technique (Luque de Castro and Priego-Capote 2010). In this method the solid particles are placed in a cotton sampler inside a vertical extraction chamber. The lower part of the chamber is connected with a spherical flask together with large quantities of the solvent system and it is placed in a heater mantle. The upper part is connected with a condenser that uses a water supply as the refrigerant. The solvent reflux and siphon principle that happens during this process are responsible for extraction with a pure solvent every time, leading to significant higher extraction efficiency than the other extraction methods. Soxhlet extraction was performed for 6 hours at the boiling point of each solvent system.

UAE is a technique that combines high power and low frequency sound waves in order to bring imbalance to the plant matrix and thus increasing the penetration of the solvent to the cellular structure. This combination leads to the creation of high/low pressure cycles and produces cavitation bubbles. When these bubbles collapse, they provide the system with energy that enables the detachment of the bioactive compound from the plant matrix (Laina et al. 2021). The experiments were performed in the Ultrasonic reaction system XO-SM50 (Nanjing Xianou Instruments Manufacture CO., LTD., China) for different times (5 min, 10 min) and different intensities (50 %, 100 % or otherwise 450 W, 900 W). For all the experiments the stirrer was set at 1000 rpm and the Ultrasonicator was on for 4 s (spraying duration) and off for 1 s (time between the spraying). Conventional extraction was performed on a hot plate at different temperatures (40 °C, 60 °C) and different times (60 min, 90 min) by continuous stirring at 1000 rpm.

The extracts were centrifuged (Centrifuge Avanti™ J-25, centrifuge cage JLA 16.250, Beckmann Coulter) and stored in plastic tubes in -20 °C for further use.

## 2.3 Properties

### Total Phenolic Content

The total phenolic content (TPC) of the silverskin extracts was determined by the Folin-Ciocalteu assay (Skotti et al. 2014) with some modifications. Briefly, 0.1 mL of each sample, 0.5 mL of Folin-Ciocalteu reagent and 7.9 mL of deionized water were transferred in a 10 mL flask and mixed in vortex. Then 1.5 mL of 25 % saturated  $\text{Na}_2\text{CO}_2$  was added in the flask, mixed thoroughly again, and let standing in the dark, at room temperature for 2 hours. Absorbance was measured by a spectrophotometer (Spectrometer 211 UV-M51, Bel Photonics) at 765 nm against a blank. The total phenolic contents were calculated according to the calibration curve of gallic acid, and expressed as gallic acid equivalents (GAE) in milligrams per gram of the initial dried raw material. All measurements were performed in duplicate.

### Extraction yield

For the extraction yield measurement, the solvent system was removed in a Rotary evaporator (Buchi R-200 Rotavapor System, Switzerland) with a vacuum controller V-800 set at 100mbar and a heating bath B-490 set at 60 °C. Then, the samples were left to dry in a vacuum oven (Vacuum Dying Oven BOV-50V, Biobase Biodustry Shandong Co., Ltd, China) for 3 hours, at 50 °C. The extraction yield percentage was determined by the following equation Eq (1):

$$\text{Extraction yield} = \frac{\text{Dry extract (g)}}{\text{Raw material (g)}} \times 100 \quad (1)$$

## 3. Results and discussion

### 3.1. Simulation of an ORC in Aspen simulation

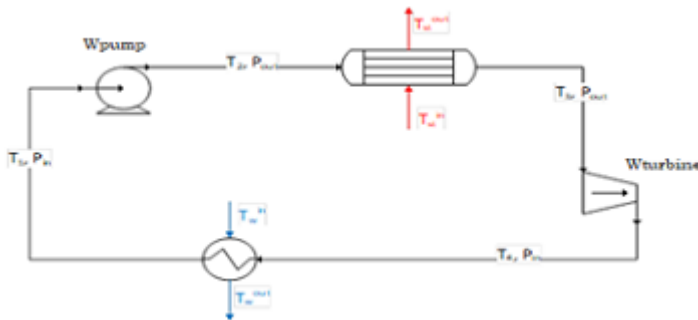

Figure 2. Organic Rankine Cycle

Energy balances for ORC (Figure 2) heat exchangers (evaporator and condenser) are based on assumptions that the system experiences no heat losses, that it is isobaric, and that it experiences a temperature difference of at least 10 °C. Considering a constant set point temperature and ignoring the small variation in supply temperature, the cycle calculations have been performed. Table 2 summarizes the optimal operating parameters in Aspen simulation. The  $W_{\text{ORC}}$  is calculated by subtracting the  $W_{\text{pump}}$  from  $W_{\text{turbine}}$ .

Table 2: Optimal operating parameters of ORC in each case study in Aspen Plus

Case study	Working fluid	T1 (°C)	T2 (°C)	T3 (°C)	T4 (°C)	P <sub>in</sub> (bar)	P <sub>out</sub> (bar)	T <sub>st,in</sub> (°C)	T <sub>st,out</sub> (°C)	T <sub>w,in</sub> (°C)	T <sub>w,out</sub> (°C)	W <sub>pump</sub> (kWh)	W <sub>turbine</sub> (kWh)	W <sub>ORC</sub> (kWh)
Small scale	Water	30	30.2	151.8	61.6	1	8	720	40.6	15	25	0.35	30	29.65
Large scale	R1234ZE	41.6	47.6	125.2	72	1	5	400	189.2	15	30	2	27	25

The simulation results indicate that an installation of an ORC to utilize the discarded heat from the afterburner will be more efficient in a small-scale coffee plant. In case study 1 the electrical energy in one hour of operation of the ORC is higher than the energy produced in the large-scale plant. This is due to the difference of available thermal energy for each case study. The available thermal energy is proportional to the temperature, as well as the mass flow of air that enters the heat exchanger of the ORC. More specifically, the observed differences in the values of temperature and mass flow are attributed to the type of afterburner and the recycling of the hot stream before its entrance to the afterburner only in case study 2, respectively.

The investment cost for the installation of an ORC, connected to the afterburner, is about 140,000 €, according to Pantaleo (2018). However, the European Union encourages businesses and provides funding for the implementation of clean energy practices and thus, the investment cost of the ORC may plummet significantly (Lyons et al. 2022). A small-scale plant can generate approximately 62,000 kWh/per year and a large-scale plant can generate approximately 52,000 kWh (assuming both factories work for 8h a day/260 a year). According to Eurostat (2022), the average electricity prices for non-household consumers in European Union were 0.2104 € per kWh in 2022, meaning that the profits from selling the generated energy will be around 13,000 € per year for case study 1 and around 11,000 € per year for case study 2. Assuming that the cost of the installation is 140,000 € and the coffee plants do not get funding from the European Union, the depreciation for case study 1 and 2 will be realized in approximately 11 years and 13 years, respectively.

### 3.2. Silverskin extraction yield and Total phenolic content

Table 3: Soxhlet extraction

Extraction solvent system	Solid:Solvent ratio	Duration (min)	Number of siphons	Extraction yield (g dry extract/g raw material)
Ethanol 50:50 Water	1:50	360	30	25.19 %
Methanol 80:20 Water	1:50	360	26	25.38 %

Table 4: Extraction with hot plate and magnetic stirring

Extraction solvent system	Solid:Solvent ratio	Duration (min)	Temperature (°C)	Extraction yield (g dry extract/g raw material)	TPC (mg GAE/g raw material)
Ethanol 50:50 Water	1:50	60	40	16.10 %	41.695
Ethanol 50:50 Water	1:50	90	60	16.84 %	56.469
Methanol 80:20 Water	1:50	60	40	14.41 %	42.115
Methanol 80:20 Water	1:50	90	60	14.69 %	58.796

Table 5: Ultrasonic assisted extraction (UAE)

Extraction solvent system	Solid:Solvent ratio	Duration (min)	Ultrasonic intensity (W)	Extraction yield (g dry extract/ g raw material)	TPC (mg GAE/g raw material)
Ethanol 50:50 Water	1:50	5	450	16.32 %	36.492
Ethanol 50:50 Water	1:50	5	900	16.51 %	27.896
Ethanol 50:50 Water	1:50	10	450	16.39 %	34.165
Ethanol 50:50 Water	1:50	10	900	16.88 %	32.581
Methanol 80:20 Water	1:50	5	450	15.54 %	39.950
Methanol 80:20 Water	1:50	5	900	16.11 %	26.441
Methanol 80:20 Water	1:50	10	450	16.17 %	22.079
Methanol 80:20 Water	1:50	10	900	16.22 %	25.730

Soxhlet extraction was used to measure the maximum extraction yield, which was found to be around 25 % g dry extract/g raw material, due to its higher extraction duration. Conventional extraction and the UAE exhibited similar results regarding the extraction yield in all studied parameters, with the highest TPC value (58.796 mg GAE/g raw material) observed in conventional method at 60 °C for 90 minutes with Methanol:Water (80:20) as a solvent system. However, higher values of TPC were obtained with the conventional extraction, which can be attributed to longer extraction times and the formation of free radicals during UAE that react with phenolic compounds, reducing the final TPC values. Additionally, the equipment cost of UAE is much higher compared to the conventional extraction, but it possesses the ability to produce larger amount of extracts in the same operating time. Thus, due to its productivity, UAE would be a more appealing method a large-scale plant generating significant amounts of silverskin as a waste. With an extraction yield approximately 16.5 % the coffee plants can produce 0.165 g extract/1g silverskin. Therefore, for the case study 1 and 2 the annual production of extract is approximately 360 kg and 720 kg, respectively. Additionally, silverskin extract consists of chlorogenic acid ranging between 1 % and 6 % (Iriando-DeHond et al. 2017). The average market price of a coffee extract containing 50% chlorogenic acid ranges between 30-40 € per kg, thus the market price of the produced extracts can vary from 4.0 to 5.3 € per kg. A preliminary investigation was conducted to estimate the potential revenue generated from the sale of the produced extracts, taking into consideration the aforementioned commercial prices. The research findings indicated that studies 1 and 2 have the potential to generate annual revenues ranging from 1,400 to 1,900 € and 2,800 to 3,800 €, respectively. It is important to note that the cost of equipment and extraction solvents were not considered in this study.

### 4. Conclusions

In the context of circular economy and sustainability the coffee industry can valorize the wastes produced from the roasting stage in order to reduce the energy consumption and gain additional profits. At the same time, the utilization of the by-products can help with the waste managing of the plant and subsequently reduce its carbon footprint. The technology of ORC is an efficient way to utilize the waste heat from the afterburner to generate clean energy that the plant can sell back to the grid and thus, minimize the electric energy resulting from non-renewable resources. Both large and small scale coffee roasting plants, can benefit from the implementation of ORC in their process for the recovery of energy from the waste heat in the flu gases.

However, the effect is more significant in the small-scale plant where no gas stream is recycled and the temperature of the flu gas is much higher due to the thermal afterburner utilization. For larger plants the recovery of bioactive compounds from the silverskin byproduct can be proved profitable since the extract (obtained through UAE with considerable efficiency) can be used either within the company for enhancing different product properties (e.g. aroma, flavor) or sold as additive to the food market.

### Acknowledgments

This work was financed by the project "CIRCULAR ECONOMY STUDY - ENERGY SAVINGS IN THE PRODUCTION OF PROCESSED COFFEE AND UTILIZATION STUDY" that is financed by Greek national funds through the Operational Program "Attiki 2014-2020" of the National Strategic Reference Framework (NSRF) - Research Funding Program.

### References

- Costa A.S.G., Alves R.C, Vinha A.F., Costa E., Costa C.S.G., Nunes M.A., Almeida A.A., Santos-Silva A, Oliveira M.B.P.P, 2018, Nutritional, Chemical and Antioxidant/pro-Oxidant Profiles of Silverskin, a Coffee Roasting by-Product, *Food Chemistry*, 267, 28–35.
- Costabile, Adele, Kittiwadee Sarnsamak, and Astrid C. Hauge-Evans, 2018, Coffee, Type 2 Diabetes and Pancreatic Islet Function – A Mini-Review, *Journal of Functional Foods*, 45, 409–16.
- Eurostat, 2022, Electricity Price Statistics <[https://ec.europa.eu/eurostat/statistics-explained/index.php?title=Electricity\\_price\\_statistics#Electricity\\_prices\\_for\\_non-household\\_consumers](https://ec.europa.eu/eurostat/statistics-explained/index.php?title=Electricity_price_statistics#Electricity_prices_for_non-household_consumers)> accessed 23.06.2023.
- INTERNATIONAL COFFEE ORGANIZATION, 2020, World coffee consumption < [http://www.ico.org/trade\\_statistics.asp?section=Statistics](http://www.ico.org/trade_statistics.asp?section=Statistics)> accessed 23.06.2023.
- Iriondo-DeHond, A., Fernández-Gómez, B., Martínez Sáez, N., Martirosyan, D.M., Mesa, M.D., Castillo, M, 2017, Coffee Silverskin: A Low-Cost Substrate for Bioproduction of High-Value Health Promoting Products, 1, 1005.
- Laina, Konstantina M., Panagiota N. Eleni, Konstantina G. Tsitseli, and Magdalini K. Krokida, 2021, Process Design for the Extraction of Bioactive Compounds from Several Mediterranean Medicinal Plants, *Chemical Engineering Transactions* 86: 1327–32.
- Liang, N., Kitts, D.D., 2014, Antioxidant Property of Coffee Components: Assessment of Methods That Define Mechanism of Action, *Molecules*, 19, 19180–19208
- Luque de Castro M.D., and Priego-Capote F., 2010, M.D. Soxhlet extraction: Past and present panacea, *Journal of Chromatography A*, Vol. 1217, 16, 2383-2389A.
- Lyons, L., Georgakaki, A., Kuokkanen, A., Letout, S., Mountraki, A., Ince, E., Shtjefni, D., Joanny Ordonez, G., Eulaerts, O. and Grabowska, M., 2022, Clean Energy Technology Observatory: Heat Pumps in the European Union, Status Report on Technology Development, Trends, Value Chains and Markets, EUR 31268 EN, Publications Office of the European Union, Luxembourg, ISBN 978-92-76-58572-5
- Markides C.N., 2013, The Role of Pumped and Waste Heat Technologies in a High-Efficiency Sustainable Energy Future for the UK., *Applied Thermal Engineering*, 53, 197–209.
- Murthy P.S, Naidu M.M., 2012, Recovery of Phenolic Antioxidants and Functional Compounds from Coffee Industry By-Products, *Food and Bioprocess Technology*, 5, 897–903.
- Mussatto, S.I., Machado E.M.S., Martins S., Teixeira J.A., 2011, Production, Composition, and Application of Coffee and Its Industrial Residues, *Food and Bioprocess Technology*, 4, 661-672
- Ong'iro, A O, V I Ugursal, A M Ai Taweel, and D K Blamire., 1995, SIMULATION OF COMBINED CYCLE POWER PLANTS USING THE ASPEN PLUS SHELL, *Heat Recovery System & CIIP*. Vol. 15.
- Pantaleo A. M, Julia Fordham, Oyenyi A Oyewunmi, Pietro De Palma, and Christos N Markides, 2018, Integrating Cogeneration and Intermittent Waste-Heat Recovery in Food Processing: Microturbines vs. ORC Systems in the Coffee Roasting Industry, *Applied Energy*, 225, 782–96.
- Sargent A., Watson J., Topoglu Y., Ye H., Suri R., Ayaz H., 2020, Impact of Tea and Coffee Consumption on Cognitive Performance: An FNIRS and EDA Study, *Applied Sciences*, 10, 2390
- Schwartzberg, Henry., 2013, Batch Coffee Roasting; Roasting Energy Use; Reducing That Use, In *Food Engineering Series*, 173–195.
- Skotti, E., Anastasaki E., Kanellou G., Polissiou M., Tarantilis P.A., 2014, Total Phenolic Content, Antioxidant Activity and Toxicity of Aqueous Extracts from Selected Greek Medicinal and Aromatic Plants. *Industrial Crops and Products*, 53, 46–54.